

Options

Overview of available versions

Abbreviations	Meaning	Helical gear units	Parallel shaft gear units	Bevel gear units	Worm gear units
Without	Solid shaft, foot mounting	✓		✓	✓
A	Hollow shaft		✓		
AF	Hollow shaft, B5 flange		✓	✓ ⁵⁾	✓
AX	Hollow shaft, foot mounting		✓ ¹⁾	✓	
AXF	Hollow shaft, foot mounting, flange B5			✓	
AXZ	Hollow shaft, foot mounting, flange B14			✓	
AZ	Hollow shaft, B14 flange		✓ ¹⁾	✓ ⁵⁾	✓
AZD	Hollow shaft, flange B14, with torque arm			✓ ²⁾⁵⁾	✓
AZK	Hollow shaft, flange B14, with torque bracket			✓	
B	Fixing elements for hollow shaft		✓	✓	✓
E	Single stage	✓			
EA	Splined hollow shaft, DIN 5480		✓ ⁴⁾	✓	
EF	Single stage, flange B5	✓			
F	Full shaft, B5 flange	✓			
G	Rubber buffer for torque arm		✓		
H	Cover as a touch guard		✓	✓	✓
IEC	Adapter for fitting B5 IEC standard motors	✓	✓	✓	✓
LX	Solid shaft - both sides, foot mounting			✓	✓
MK	Motor bracket	✓	✓	✓	✓
R	Integrated backstop			✓	
RLS	Backstop in W adapter	✓	✓	✓	✓
S	Hollow shaft with shrink disc		✓	✓	✓
SEK	Servo adapter with clamp coupling	✓	✓	✓	✓
SEP	Servo adapter with parallel key coupling	✓	✓	✓	✓
V	Solid shaft		✓		
VF	Solid shaft, B5 flange		✓	✓ ⁵⁾	✓
VL	Reinforced bearings	✓	✓	✓	✓
VL2	Agitator version		✓	✓	
VL3	Agitator version with "Drywell"		✓	✓	
VX	Solid shaft, foot mounting		✓ ¹⁾		
VXF	Solid shaft, foot mounting, flange B5			✓	
VXZ	Solid shaft, foot mounting, flange B14			✓	
VZ	Solid shaft, B14 flange		✓ ¹⁾	✓ ⁵⁾	
W	Drive cylinder with free input shaft	✓	✓	✓	✓
XF	Solid shaft, foot mounting, flange B5	✓ ³⁾			
XZ	Solid shaft, foot mounting, flange B14	✓ ³⁾			

✓ Available versions are marked with a tick

- 1) SK xx82NB and higher incl. SK 9282 with footrails machined on their sides for base plate
- 2) Available up to and including SK 9072.1
- 3) Available up to and including SK 52
- 4) Not available for types SK xx82NB
- 5) Versions have additional threaded holes in the underside of the housing. These are not suitable for mounting the gear unit, but rather for mounting a torque bracket → E 147.

Options

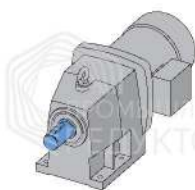

Shaft options

Solid shaft (V)

NORD standard shafts with parallel keys have a threaded hole in the face side. The shafts are available in metric dimensions and in inch dimensions on request. The standard material is C45.



Hollow shaft (A)

Standard hollow shafts with parallel keys are made from C45. Many NORD geared motors are available with various shaft diameters.

Hollow shaft with internal spline (EA)

Hollow shafts with metric spline profiles as per DIN 5480 are available for many NORD geared motors with hollow shafts. These splined shafts are often used for crane travel drives.



Shrink disc (S)

The shrink disc is based on a tried-and-tested clamping principle and enables torque transfer by friction, by converting the tightening force of the clamping screws into a radial pressure between the shaft and the hub, which results in shrinking onto the customer's shaft. Shrink discs enable a force fit which is completely free of play, and which can transfer large torques, in contrast with other types of mounting. Shrink discs do not wear, even with frequent changes of load or direction of rotation.

Shrink discs provide the following advantages:

- No corrosion of the mating surface, in contrast with parallel key couplings
- Easy assembly and dismantling
- Often larger hole diameters are possible than for hollow shafts with parallel keys

See ⇒ [A32](#) for details

Reinforced shrink disc (VS)

The NORD reinforced shrink disc provides greater clamping force and therefore greater safety. See ⇒ [A32](#) for details

Reinforced output bearings (VL)

The use of reinforced output bearings with increased load bearing capacity enables higher external loads (radial/axial) to be absorbed. Please consult us in case of predominantly greater axial loads.



Torque arm (D)

A torque arm is a compact, simple solution to secure a geared motor with a hollow shaft. It is bolted to the B14 flange of the geared motor. The torque arm has a rubber bushing on the attachment hole which absorbs the load impulses.



Torque bracket (K)

A torque bracket is a compact, simple solution to secure a face-mounted geared motor. It is bolted to the underside of the gear unit. The torque bracket has a rubber bushing on the attachment hole which absorbs the load impulses.

Hollow shaft cover (H)

An optional cover for the rotating hollow shaft is available. This also protects the output shaft against dust and dirt.

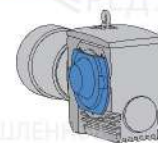

Shrink disc cover (SH)

A shrink disc cover is required for all shrink disc gear units and provides protection from the rotating shrink disc.



IP66 Hollow shaft cover (H66)

NORD supplies hollow shaft covers in protection class IP66 (protection against dust and splashed water). The rotating hollow shaft is completely sealed against humidity and foreign bodies.

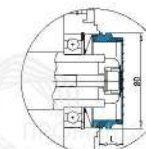

Fastening element (B)

As small vibrations occur with all shafts, NORD supplies an optional fastening kit. This prevents the geared motor from changing its position in an axial direction. The fastening kit can be mounted in two different ways. See → A37 for details

Rubber buffer (G)

Two rubber buffers are mounted on the torque bracket and on the torque arm. They are used to damp torsional load impulses which act on the geared motor. As the rubber buffers reduce the overall torsional load impulses, their use can increase the service life of the geared motor. The damping effect can be increased by the use of several buffers in series. The permissible temperature range for the use of rubber buffers is from -40°C ... $+80^{\circ}\text{C}$.

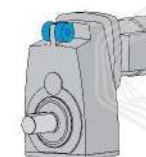

For further damping, several rubber buffers may be used in series.

Total damping travel: $s_{FD\text{ tot}} = n \times s_{FD}$ [mm]

s_{FD} Damping travel of a rubber buffer [mm]

n Number of rubber buffers used in series

Rubber buffers are supplied in pairs.

During installation, the rubber buffer may **only** be tightened until the play between the contact surfaces is eliminated. Pre-tensioning of the rubber buffer is not permissible!

Technical data → D96, E113, E115, E117, E119



Reinforced rubber buffer (VG)

Rubber buffers are optionally available as reinforced type VG versions for parallel shaft gear units with face mounted designs.

Bevel helical gearboxes from size SK 9082.1 are supplied in the AZK version with rubber buffers.

F_D Compressive force acting on rubber buffer [kN]

c width

s_{FD} Damping travel of a rubber buffer

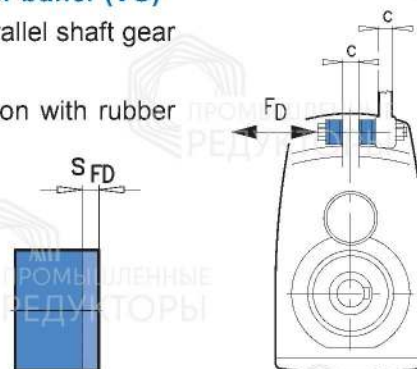

Standards, Regulations Nomenclature

Bevel gear units

Sizes



2-stage	3-stage	4-stage	5-stage	6-stage
			Double gear units	
SK 92072.1	SK 9012.1	SK 9013.1		
SK 92172.1	SK 9016.1	SK 9017.1		
SK 92372.1	SK 9022.1	SK 9023.1		
SK 92672.1	SK 9032.1	SK 9033.1		
SK 92772.1	SK 9042.1	SK 9043.1		
	SK 9052.1	SK 9053.1		
	SK 9072.1		SK 9072.1/32, SK 9072.1/42	
	SK 9082.1		SK 9082.1/42, SK 9082.1/52	
	SK 9086.1		SK 9086.1/52	
	SK 9092.1		SK 9092.1/52	
	SK 9096.1		SK 9096.1/62	SK 9096.1/63

Order examples:

SK 92372.1 L X - 80 LH/4

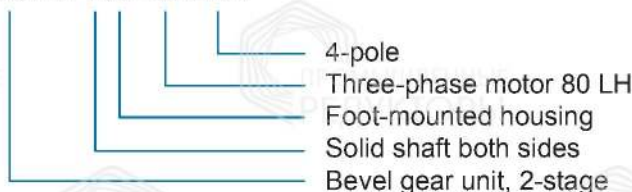

SK 9033.1 A F - W

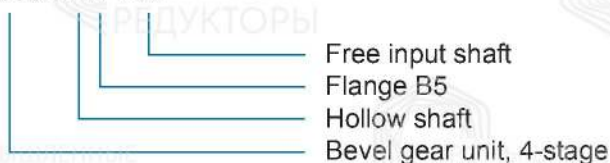

SK 9086.1/52 A Z K - IEC 160

